



Installation and Maintenance Instructions

Elevated Light – type 241

Preface

- Please read carefully and understand the contents of this manual.
- Failure to read the manual may result in serious injury, or serious damage to equipment.
- Make sure these instructions are always accessible for all users and ensure that you have read and understood the contents.

Document Information

Name : **05_LED_AGL_Elevated_Light_Type_241_03-71090**

Version	Date	Description
V2.1	10-11-2023	Original
V2.2	29-02-2024	Spare Parts update
V2.3	14-05-2025	Changed IP rating to IP64
V2.4	22-04-2026	Updated maintenance instructions

The English version of this document is the original version; this language version is verified by the manufacturer. All other language versions are translations of the original English language version. For the latest version of this document see <https://www.tkh-airportsolutions.com/airfield-products/> or scan:



Copyright © TKH Airport Solutions 2026

All rights reserved for TKH Airport Solutions. No part of this publication may be reproduced, modified, stored in a retrieval system, or transmitted, by any means or in any form without the written permission of the copyright owner.

The content of this document is property of TKH Airport Solutions. Proprietary rights of TKH Airport Solutions B.V. or USE System Engineering Holding B.V. or their affiliated companies include the following: The specified (product) information herein and all related data and information are proprietary and confidential to TKH Airport Solutions B.V. or USE System Engineering Holding B.V. and are the subject of trade secrets and copy licensed from TKH Airport Solutions B.V. or USE System Engineering Holding B.V. The related data and information are provided in confidence, and all use, disclosure, copying, transfer and storage, except as authorized in the written License Agreement from TKH Airport Solutions B.V or USE System Engineering Holding B.V. to the user, is strictly prohibited.

Contents

1. About this manual	4
1.1 Symbols used	4
1.2 Storing the manual	5
1.3 Limitations of the Document	5
1.4 Terms and Abbreviations.....	6
1.5 Liability and Warranty	6
1.6 Manufacturer Details	6
2. Safety	7
2.1 Safety.....	7
2.2 Qualified Personnel	7
2.3 Intended use.....	8
2.4 Installation.....	8
2.5 Operation	9
2.6 Action in the event of a system or component malfunction	9
3. General Recommendations	10
3.1 Receiving, Storage and Unpacking	10
3.2 Electrical Connection.....	10
3.3 Base Earthing	10
4. About the Elevated Light - type 241	11
4.1 Operation Information.....	11
4.2 Elevated Light - type 241: Spare Parts.....	12
4.3 Electronics	13
4.4 Main Dimensions	13
4.5 More Information	13
5. Installation	14
5.1 Unpacking the Light Fixtures	14
5.2 Installation in the Field.....	14
6. Maintenance.....	15
6.1 Warranty Limitation.....	15
6.2 In the Field Maintenance	15
6.3 Preventive Maintenance.....	15
6.4 Corrective Maintenance.....	16

1. About this manual

This manual contains information about the installation and maintenance of the LED AGL Elevated Light – type 241.

1.1 Symbols used

The following marking conventions are used in this manual to draw attention to specific topics or actions:



DANGER! - This sign indicates a hazardous situation that, if not avoided, will result in death or serious injury.



WARNING - This sign indicates a hazardous situation that, if not avoided, could result in death or serious injury.











CAUTION - This sign indicates a hazardous situation that, if not avoided, could result in minor or moderate injury.

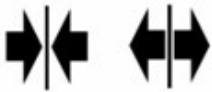

NOTICE - is used in this manual to indicate a situation that could result in damage to property or equipment.

The following symbols are used in pictures for explanation or an action:

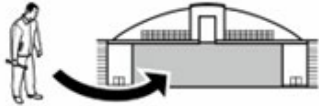
Correct / Incorrect 	Look / See 	Location / position 	Movement 
Connect / Disconnect 	Photobiological safety 	ESD warning 	
Work carried out on runway 		Work carried out in workshop 	

The following symbols are used on equipment and in this manual to warn of potential hazards:



DANGER of electrical shock or arc flash. Failure to observe this warning will result in serious injury or death.



WARNING or CAUTION: where this symbol is used on the equipment, it is mandatory to consult the manual to find out the nature of potential hazards and any actions which have to be taken to avoid them.

1.2 Storing the manual

- This manual is a part of your product. Store the manual in a location that can be easily accessed by personnel working on the product.
- It is the responsibility of the company operating this equipment to ensure that its personnel is provided with a copy of this manual.

1.3 Limitations of the Document

TKH Airport Solutions reserves the right to revise this document without notification.

The data provided in this document is based on the most recent information at the time of publication. TKH Airport Solutions is continually seeking to ensure that its products are developed to the latest technological standards. As a result, it is possible that there may be some differences between the product and the information in this manual.

For further information regarding adjustment, maintenance or repair which is not described in this document, please contact the Customer Service department of TKH Airport Solutions.

The information in this document concentrates solely on use of the products as intended by the manufacturer.

1.4 Terms and Abbreviations

This document may include the terms and abbreviations as listed below.

AGL	Airfield Ground Lighting
EASA	European Aviation Safety Agency
ICAO	International Civil Aviation Organization
IEC	International Electrotechnical Committee
LED	Light Emitting Diode

1.5 Liability and Warranty

TKH Airport Solutions cannot be held responsible for injuries or damage resulting from non-standard, unintended use, faulty or improper installation of its equipment, or failure to follow the instructions and safety guidelines in this manual. The safety of any system incorporating the Elevated Light- type 241 is the responsibility of any site installation, commissioning, maintenance, and operational personnel using the system.

NOTICE

Disregarding the safety instructions in this manual will result in the loss of warranty in case of damage.

Refer to the general TKH Airport Solutions Terms and Conditions document supplied with your sales order contract for a complete liability and warranty description.

1.6 Manufacturer Details

TKH Airport Solutions

Elektrostraat 17
7483 PG Haaksbergen
The Netherlands

- Tel.: +31 (0)53 5741456
- Email: info@tkh-airportsolutions.com
- Internet: www.tkh-airportsolutions.com

For service requests, please contact the TKH Airport Solutions Customer Service department:

- Email: service@tkh-airportsolutions.com

2. Safety

2.1 Safety



This section contains general safety instructions for using your TKH Airport Solutions equipment. Some safety instructions may not apply to the equipment in this manual. Note all warnings and follow all instructions carefully. Failure to do so may result in personal injury, death, or property damage.

To use this equipment safely,

- Refer to the International Standard IEC 61820, Electrical installation for lighting and beaconing of aerodromes - Constant current series circuits for aeronautical ground lighting - System design and installation requirements, and to the International Standard IEC 61821, Electrical installations for lighting and beaconing of aerodromes - Maintenance of aeronautical ground lighting constant current series circuits for instructions on safety precautions.
- Observe all safety regulations. To avoid injuries, always remove power prior to making any wire connections and touching any live part. Refer to the International Standards IEC 61820 & IEC 61821.
- Read and become familiar with the general safety instructions provided in this section of the manual before installing, operating, maintaining, or repairing this equipment.
- Read and carefully follow the instructions given throughout this manual for performing specific tasks and working with specific equipment.
- Store this manual within easy reach of personnel installing, operating, maintaining, or repairing this equipment.
- Follow all applicable safety procedures required by your company, industry standards, and government or other regulatory agencies.

2.2 Qualified Personnel

The term "qualified personnel" is defined here as a person who thoroughly understands the equipment and its safe installation, operation, maintenance, and repair. Qualified personnel are physically capable of performing the required tasks, familiar with all relevant safety rules and regulations, and have been trained to safely install, operate, maintain, and repair the equipment. It is the responsibility of the company installing, operating or maintaining this equipment to ensure that its personnel meet these requirements.

2.3 Intended use



DANGER!

Use of this equipment in ways other than described in the datasheet and this manual may result in personal injury, death, or property damage. TKH Airport Solutions cannot be held responsible for injuries or damage resulting from non-standard, unintended application of its equipment. This equipment is designed and intended only for the purpose described in this manual. Uses not described in this manual are considered to be unintended use. Unintended use may result from taking the following actions:

- making changes to equipment that have not been recommended or described in this manual or using parts that are not genuine TKH Airport Solutions replacement parts or accessories
- using materials or auxiliary equipment that are inappropriate or incompatible with your TKH Airport Solutions equipment
- allowing unqualified personnel to perform any task

2.4 Installation



WARNING

A thorough understanding of system components and their requirements will help you install the system safely and efficiently. Failure to follow these safety procedures can result in personal injury or death.

NOTICE

Read the safety and installation sections of all system component manuals before installing your equipment.

- Allow only qualified personnel to install TKH Airport Solutions equipment and auxiliary equipment. Use only approved equipment. Using unapproved equipment in an approved system may void agency approvals and will void the warranty.
- Make sure all equipment is rated and approved for the environment in which you are using it.
- Follow all instructions for installing components and accessories.
- Do not hold or carry the light assemblies by the cables.
- Install all electrical connections according to local codes and regulations, provided they are not in contradiction with the general rules.
- Use only electrical wire of sufficient gauge and insulation to handle the rated current and voltage demand. All wiring must meet local codes.
- Route electrical wiring along a protected path. Make sure the wires will not be damaged by moving equipment and animals (e.g. rodents).
- Protect components from damage, wear, and harsh environmental conditions.
- Allow sufficient room for maintenance, panel accessibility (power products), and cover removal (power products).
- Protect equipment with safety devices as specified by applicable safety regulations.
- If safety devices must be removed for maintenance, re-install them immediately after the work is completed and check them for proper functioning.

2.5 Operation



Only qualified personnel (see section Qualified Personnel) should operate this equipment. Read all system component manuals before operating this equipment. A thorough understanding of system components and their operation will help you operate the system safely and efficiently.

- Before starting this equipment, check all safety interlocks, fire-detection systems, and protective devices such as panels and covers. Make sure all devices are fully functional. Do not operate the system if these devices are not working properly. Do not deactivate or bypass automatic safety interlocks or locked-out electrical disconnects or pneumatic valves.
- Never operate equipment with a known malfunction.
- Do not attempt to operate or service electrical equipment if standing water is present.
- Use this equipment only in the environments for which it is rated. Do not operate this equipment in humid, flammable, or explosive environments unless it has been rated for safe operation in these environments.
- Never touch exposed electrical connections on equipment while the power is ON.
- Never look directly in the light source while the power is ON.

2.6 Action in the event of a system or component malfunction



Do not operate a system that contains malfunctioning components. If a component malfunctions, turn the system OFF immediately.

- Disconnect and lock out electrical power.
- Allow only qualified personnel to make repairs. Repair or replace the malfunctioning component according to instructions provided in its manual. Allow only qualified personnel to perform maintenance, troubleshooting, and repair tasks. Only persons who are properly trained and familiar with TKH Airport Solutions equipment are permitted to service this equipment.
- Follow the recommended maintenance procedures in your equipment manuals.
- Connect all disconnected equipment ground cables and wires after servicing equipment. Ground all conductive equipment.
- Use only approved TKH Airport Solutions replacement parts. Using unapproved parts or making unapproved modifications to equipment may void agency approvals, impair specified performance and create safety hazards.
- Check interlock systems periodically to ensure their effectiveness.
- Do not attempt to service electrical equipment if standing water is present. Use caution when servicing electrical equipment in a high-humidity environment.
- Use tools with insulated handles when working with electrical equipment.

3. General Recommendations

3.1 Receiving, Storage and Unpacking

- 1 Upon receipt of goods at the site store, check all packaging for visible damage. Every damaged box should be opened and its contents inspected for damage. If equipment is damaged, a claim form shall be filled with the carrier immediately. It may then be necessary for the carrier to inspect the equipment.
- 2 Store the light assembly preferably in its original packaging in a protected area. When stored unpacked, please take care not to damage the cable insulation.
- 3 Unpack the light assembly at the installation site to avoid damage during transportation and handling.

3.2 Electrical Connection

The light assemblies covered by this manual are designed for connection to 6.6-A series circuits via one or two L-830 or L-831 series transformers. The current to the light should not exceed 6.6 A + 5%. The series transformers are to be ordered separately.

3.3 Base Earthing

Whatever the chosen installation method, it is strongly recommended to earth the base, especially in locations presenting a risk of lightning strikes. Failure to earth the base correctly will void the warranty for all damages occurring as a result of voltage surges.

4. About the Elevated Light - type 241

TKH Airport Solutions LED AGL Elevated Light - type 241 is constructed mainly by using standard components from TKH Airport Solutions standard program of elevated fixtures.

The light output is omnidirectional, in blue, green or white. The color of the LED output together with the colored lens glass defines the correct color.

The fixture has a breakable coupling, designed for 2" (60 mm) pole mounting (Type C) or with 2" thread stub (Type A).

4.1 Operation Information

The Elevated Light - type 241 is for outdoor use only for dedicated airfield installation.

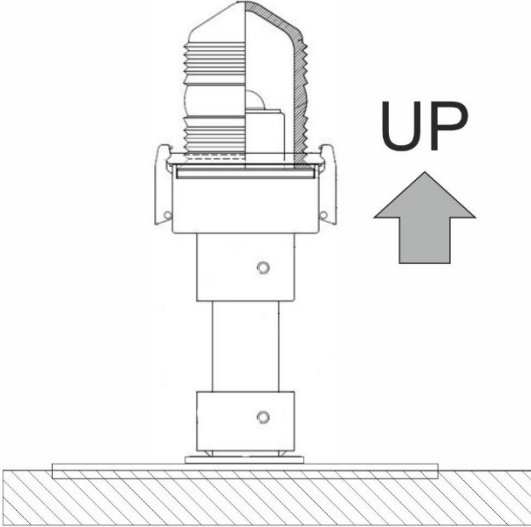
Power consumption:	max. 8 W
Rated voltage:	max. 1,7 VAC
Nominal AC frequency	40-70 Hz
Operation on constant current source:	max. 6.6 A
Ambient temperature:	-40°C (40°F) / +75°C (+167°F)
Weight:.	approx. 1.4 kg
Dust and water tightness:	IP64
Operation position: (note: drawing is indicative only)	

4.2 Elevated Light - type 241: Spare Parts

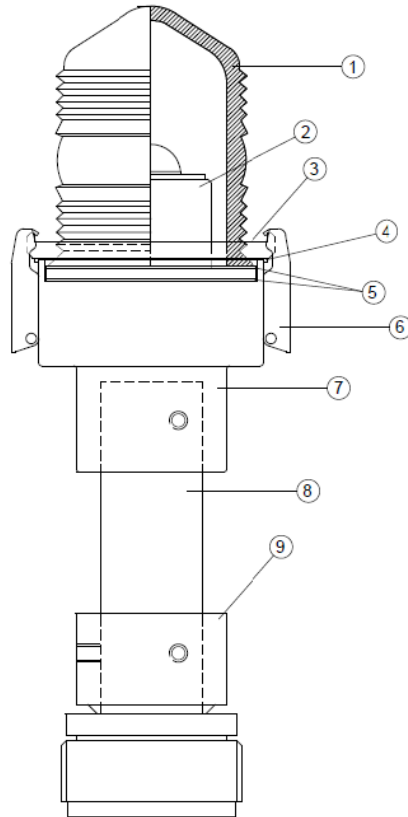

Pos.	Name	Type	Number per Light
1	Top glass blue (LED)	P-382408	0/1
	Top glass blue (Halogen)	P-382401	0/1
	Top glass green	P-382406	0/1
	Top glass clear (white)	P-382400	0/1
2	Light unit blue	241.224/1	0/1
	Light unit green	241.226	0/1
	Light unit white	241.227	0/1
3	Top ring	40-6372	1
4	Neoprene seal	841.056/2	1
5	Rubber seal	841.056	2
6	Steel clamp	P-855.010	2
7	Lamp housing	841.052/1	1
8	Transformer tube (for 260mm height)	K12003/1	0/1
	Transformer tube (for 350mm height)	K12008	0/1
9	Breakable coupling type A (2" thread)	790518/2	0/1
	Breakable coupling type C	790901/2	0/1

4.3 Electronics

The driver electronics for the LED modules are identical to the electronics used in unidirectional TKH Airport Solutions LED AGL inset and elevated light fixtures. The electronics will transfer the RMS value of the 6.6 A series circuit current into the necessary LED current. The electronics is informed about the LED current needed from the EPROM memory on the LED module.

4.4 Main Dimensions

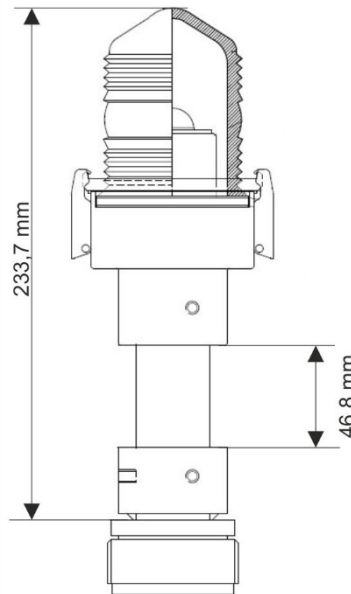

4.5 More Information

For technical data refer to the datasheet for your product at <https://www.tkh-airportsolutions.com/airfieldproducts/> or scan:



If you have any questions about installation or maintenance, please contact TKH Airport Solutions Customer Service on service@tkh-airportsolutions.com.

5. Installation

5.1 Unpacking the Light Fixtures

The Elevated Light - type 241 fixtures are supplied in individual boxes.

Please make sure that nothing is broken before starting installation.

5.2 Installation in the Field

The light fixtures can be installed on a base plate or tube.

1. Connect the light fixture using screw terminals or via a standard 2-pole FAA connector (style 1).
2. Mount the fixture in the breakable coupling.
3. Tighten the screws in the breakable coupling to the torque shown below using a calibrated torque wrench.

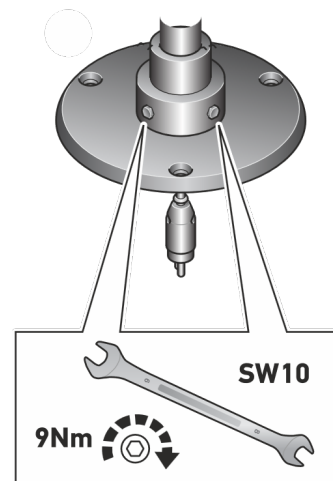
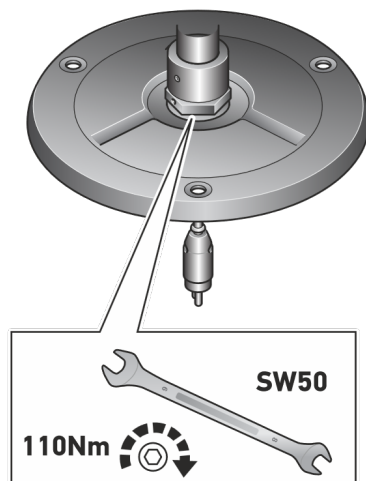

6. Maintenance

6.1 Warranty Limitation

The light assemblies are delivered fully tested and sealed. In case of malfunctioning during the warranty period, the defective light shall be shipped back to TKH Airport Solutions without opening it. Any attempt to open the light during the warranty period will void the warranty.

The lens glasses are not included in the warranty.

6.2 In the Field Maintenance

The light assemblies can be serviced in the field, but it is recommended to limit field maintenance to cleaning the front glass. It is recommended to replace the elevated lights at regular intervals and to have them overhauled in the maintenance shop. The same applies to lights found unserviceable in the field.

6.3 Preventive Maintenance

The light assembly's service life depends to a large extent on its waterproofness. All metal mating surfaces and seals must be clean, smooth, dry, and free of all foreign particles if the light fixture is to operate for extended periods without requiring maintenance. Greasing of O-ring seals may be required.

Maintenance frequency depends on the conditions under which the runway is used (i.e. climate, traffic, etc.). The recommended practices for maintenance are described in the FAA advisory circular no. AC 150/5340-26 and in the ICAO Aerodrome Design Manual, Part 9 Airport Maintenance Practices.

TKH Airport Solutions recommends performing the following preventive maintenance activities

Frequency	Preventive maintenance activity
Daily	<ul style="list-style-type: none"> Check the correct operation of the fixture; repair in case of any malfunction
Weekly	<ul style="list-style-type: none"> Visually inspect each light fixture for signs of damage, loose parts, or abnormal condition Clean the front glass and remove dust/dirt from the fixture Remove any vegetation around the fixture
Monthly	<ul style="list-style-type: none"> Inspect the optical window/prism for cleanliness, mechanical damage, and any moisture or condensation inside the prism Check whether the fixture is properly fixed in its base; re-secure if required
Yearly	<ul style="list-style-type: none"> Perform a detailed inspection of the light fixture Check for mechanical damage such as prism cracks Clean the optical windows

As needed (incidentally)	<ul style="list-style-type: none"> • After any abnormal weather events, inspect fixtures for damage. Replace any damaged fixtures, and return them for investigation and repair. Remove debris obstructing the light beam
-------------------------------------	--

6.4 Corrective Maintenance

When a light malfunctions, components can be replaced. Refer to chapter 4.2 for a spare parts list.



Company profile:

TKH Airport Solutions is an innovator in airfield ground lighting, offering a complete range of LED AGL products. We build upon the know-how from a long and successful tradition of pioneering developments in the AGL and connectivity industry. Being part of the TKH Group, our company can build on a history of more than 90 years in smart connectivity, energy distribution and AGL.

More information:

TKH Airport Solutions
sales@tkh-airportsolutions.com
www.tkh-airportsolutions.com
+31 (0)53 57 414 56

Visiting address

TKH Airport Solutions
Elektrostraat 17
7483 PG Haaksbergen
The Netherlands