



TKH  
AIRPORT  
SOLUTIONS



# Installation and Maintenance Instructions

## PAPI Halogen (801)

HALOGEN AGL  
Airfield Ground Lighting

03-71093  
V2.4

## Preface

- Please read carefully and understand the contents of this manual.
- Failure to read the manual may result in serious injury, or serious damage to equipment.
- Make sure these instructions are always accessible for all users and ensure that you have read and understood the contents.

## Document Information

Name : **05\_HALOGEN\_AGL\_PAPI\_801\_User\_Manual\_03-71093\_V2.4**

Version	Date	Description
V2.2	28.11.2023	Original
V2.3	03.12.2024	Added torque settings in chapter 6.1
V2.4	28.08.2025	Added instructions for bulb replacement

For the latest version of this document see <https://www.tkh-airportsolutions.com/airfield-products/> or scan:



## Copyright © TKH Airport Solutions 2025

All rights reserved for TKH Airport Solutions. No part of this publication may be reproduced, modified, stored in a retrieval system, or transmitted, by any means or in any form without the written permission of the copyright owner.

The content of this document is property of TKH Airport Solutions. Proprietary rights of TKH Airport Solutions B.V. or USE System Engineering Holding B.V. or their affiliated companies include the following: The specified (product) information herein and all related data and information are proprietary and confidential to TKH Airport Solutions B.V. or USE System Engineering Holding B.V. and are the subject of trade secrets and copy licensed from TKH Airport Solutions B.V. or USE System Engineering Holding B.V. The related data and information are provided in confidence, and all use, disclosure, copying, transfer and storage, except as authorized in the written License Agreement from TKH Airport Solutions B.V or USE System Engineering Holding B.V. to the user, is strictly prohibited.

The English version of this document is the original version; this language version is verified by the manufacturer. All other language versions are translations of the original English language version.

# Contents

1. About this manual .....	4
1.1 Symbols used .....	4
1.2 Storing the manual .....	5
1.3 Limitations of the Document .....	5
1.4 Terms and Abbreviations.....	6
1.5 Liability and Warranty .....	6
1.6 Manufacturer Details .....	6
2. Safety .....	7
2.1 Safety.....	7
2.2 Qualified Personnel .....	7
2.3 Intended use.....	8
2.4 Installation.....	8
2.5 Operation .....	9
2.6 Action in the event of a system or component malfunction .....	9
3. General Recommendations .....	10
3.1 Receiving, Storage and Unpacking .....	10
3.2 Electrical Connection .....	10
3.3 Base Earthing .....	10
4. About the PAPI 801.....	11
4.1 Mode of Operation .....	12
5. Description of the PAPI unit .....	13
5.1 PAPI specification.....	13
5.2 Assembly Drawing .....	15
5.3 List of spare parts .....	15
6. Installation and Maintenance .....	17
6.1 Installation instructions .....	17
6.2 Adjusting the correct light output plane .....	18
6.3 Adjusting the red filter .....	19
6.4 Maintenance .....	20
6.5 Replacing the red filter.....	21
6.6 Replacing the halogen bulb .....	23

# 1. About this manual

This manual contains technical information about the PAPI System (801). The manual is intended to be used for installation and maintenance of the PAPI units in a PAPI system with four or eight units, or in an APAPI system with two PAPI units.

## 1.1 Symbols used

The following marking conventions are used in this manual to draw attention to specific topics or actions:



**DANGER!** - This sign indicates a hazardous situation that, if not avoided, will result in death or serious injury.



**WARNING** - This sign indicates a hazardous situation that, if not avoided, could result in death or serious injury.











**CAUTION** - This sign indicates a hazardous situation that, if not avoided, could result in minor or moderate injury.



**NOTICE** - is used in this manual to indicate a situation that could result in damage to property or equipment.

The following symbols are used in pictures for explanation or an action:

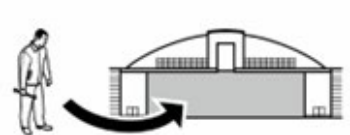
<p>Correct / Incorrect</p> 	<p>Look / See</p> 	<p>Location / position</p> 	<p>Movement</p> 
<p>Connect / Disconnect</p> 	<p>Photobiological safety</p> 	<p>ESD warning</p> 	
<p>Work carried out on runway</p> 		<p>Work carried out in workshop</p> 	

The following symbols are used on equipment and in this manual to warn of potential hazards:



**DANGER of electrical shock or arc flash.** Failure to observe this warning will result in serious injury or death.



**WARNING or CAUTION:** where this symbol is used on the equipment, it is mandatory to consult the manual to find out the nature of potential hazards and any actions which have to be taken to avoid them.

---

## 1.2 Storing the manual

---

- This manual is a part of your product. Store the manual in a location that can be easily accessed by personnel working on the product.
- It is the responsibility of the company operating this equipment to ensure that its personnel is provided with a copy of this manual.

---

## 1.3 Limitations of the Document

---

TKH Airport Solutions reserves the right to revise this document without notification.

The data provided in this document is based on the most recent information at the time of publication. TKH Airport Solutions is continually seeking to ensure that its products are developed to the latest technological standards. As a result, it is possible that there may be some differences between the product and the information in this manual.

For further information regarding adjustment, maintenance or repair which is not described in this document, please contact the Customer Service department of TKH Airport Solutions.

The information in this document concentrates solely on use of the products as intended by the manufacturer.

---

## 1.4 Terms and Abbreviations

---

This document may include the terms and abbreviations as listed below.

AGL	Airfield Ground Lighting
EASA	European Aviation Safety Agency
ICAO	International Civil Aviation Organization
IEC	International Electrotechnical Committee
LED	Light Emitting Diode
PAPI	Precision Approach Path Indicator
APAPI	Abbreviated Precision Approach Path Indicator

---

## 1.5 Liability and Warranty

---

TKH Airport Solutions cannot be held responsible for injuries or damage resulting from non-standard, unintended use, faulty or improper installation of its equipment, or failure to follow the instructions and safety guidelines in this manual. The safety of any system incorporating the PAPI System (801) is the responsibility of any site installation, commissioning, maintenance, and operational personnel using the system.

### NOTICE

Disregarding the safety instructions in this manual will result in the loss of warranty in case of damage.

Refer to the general TKH Airport Solutions Terms and Conditions document supplied with your sales order contract for a complete liability and warranty description.

---

## 1.6 Manufacturer Details

---

### TKH Airport Solutions

Elektrostraat 17  
7483 PG Haaksbergen  
The Netherlands

- Tel.: +31 (0)53 5741456
- Email: [info@tkh-airportsolutions.com](mailto:info@tkh-airportsolutions.com)
- Internet: [www.tkh-airportsolutions.com](http://www.tkh-airportsolutions.com)

For service requests, please contact the TKH Airport Solutions Customer Service department:

- Email: [service@tkh-airportsolutions.com](mailto:service@tkh-airportsolutions.com)

---

## 2. Safety

---

---

### 2.1 Safety

---



This section contains general safety instructions for using your TKH Airport Solutions equipment. Some safety instructions may not apply to the equipment in this manual. Note all warnings and follow all instructions carefully. Failure to do so may result in personal injury, death, or property damage.

To use this equipment safely,

- Refer to the International Standard IEC 61820, Electrical installation for lighting and beaconing of aerodromes - Constant current series circuits for aeronautical ground lighting - System design and installation requirements, and to the International Standard IEC 61821, Electrical installations for lighting and beaconing of aerodromes - Maintenance of aeronautical ground lighting constant current series circuits for instructions on safety precautions.
- Observe all safety regulations. To avoid injuries, always remove power prior to making any wire connections and touching any live part. Refer to the International Standards IEC 61820 & IEC 61821.
- Read and become familiar with the general safety instructions provided in this section of the manual before installing, operating, maintaining, or repairing this equipment.
- Read and carefully follow the instructions given throughout this manual for performing specific tasks and working with specific equipment.
- Store this manual within easy reach of personnel installing, operating, maintaining, or repairing this equipment.
- Follow all applicable safety procedures required by your company, industry standards, and government or other regulatory agencies.

---

### 2.2 Qualified Personnel

---

The term "qualified personnel" is defined here as a person who thoroughly understands the equipment and its safe installation, operation, maintenance, and repair. Qualified personnel are physically capable of performing the required tasks, familiar with all relevant safety rules and regulations, and have been trained to safely install, operate, maintain, and repair the equipment. It is the responsibility of the company installing, operating or maintaining this equipment to ensure that its personnel meet these requirements.

---

## 2.3 Intended use

---



### DANGER!

Use of this equipment in ways other than described in the datasheet and this manual may result in personal injury, death, or property damage. TKH Airport Solutions cannot be held responsible for injuries or damage resulting from non-standard, unintended application of its equipment. This equipment is designed and intended only for the purpose described in this manual. Uses not described in this manual are considered to be unintended use. Unintended use may result from taking the following actions:

- making changes to equipment that have not been recommended or described in this manual or using parts that are not genuine TKH Airport Solutions replacement parts or accessories
- using materials or auxiliary equipment that are inappropriate or incompatible with your TKH Airport Solutions equipment
- allowing unqualified personnel to perform any task

---

## 2.4 Installation

---



### WARNING

A thorough understanding of system components and their requirements will help you install the system safely and efficiently. Failure to follow these safety procedures can result in personal injury or death.

### NOTICE

Read the safety and installation sections of all system component manuals before installing your equipment.

- Allow only qualified personnel to install TKH Airport Solutions equipment and auxiliary equipment. Use only approved equipment. Using unapproved equipment in an approved system may void agency approvals and will void the warranty.
- Make sure all equipment is rated and approved for the environment in which you are using it.
- Follow all instructions for installing components and accessories.
- Do not hold or carry the light assemblies by the cables.
- Install all electrical connections according to local codes and regulations, provided they are not in contradiction with the general rules.
- Use only electrical wire of sufficient gauge and insulation to handle the rated current and voltage demand. All wiring must meet local codes.
- Route electrical wiring along a protected path. Make sure the wires will not be damaged by moving equipment and animals (e.g. rodents).
- Protect components from damage, wear, and harsh environmental conditions.
- Allow sufficient room for maintenance, panel accessibility (power products), and cover removal (power products).
- Protect equipment with safety devices as specified by applicable safety regulations.
- If safety devices must be removed for maintenance, re-install them immediately after the work is completed and check them for proper functioning.

## 2.5 Operation



Only qualified personnel (see section 2.2 Qualified Personnel) should operate this equipment. Read all system component manuals before operating this equipment. A thorough understanding of system components and their operation will help you operate the system safely and efficiently.

- Before starting this equipment, check all safety interlocks, fire-detection systems, and protective devices such as panels and covers. Make sure all devices are fully functional. Do not operate the system if these devices are not working properly. Do not deactivate or bypass automatic safety interlocks or locked-out electrical disconnects or pneumatic valves.
- Never operate equipment with a known malfunction.
- Do not attempt to operate or service electrical equipment if standing water is present.
- Use this equipment only in the environments for which it is rated. Do not operate this equipment in humid, flammable, or explosive environments unless it has been rated for safe operation in these environments.
- Never touch exposed electrical connections on equipment while the power is ON.
- Never look directly in the light source while the power is ON.
- For fixtures/spare parts marked with the photobiological safety symbol avoid prolonged staring in the switched ON fixture.

## 2.6 Action in the event of a system or component malfunction



Do not operate a system that contains malfunctioning components. If a component malfunctions, turn the system OFF immediately.

- Disconnect and lock out electrical power.
- Allow only qualified personnel to make repairs. Repair or replace the malfunctioning component according to instructions provided in its manual. Allow only qualified personnel to perform maintenance, troubleshooting, and repair tasks. Only persons who are properly trained and familiar with TKH Airport Solutions equipment are permitted to service this equipment.
- Follow the recommended maintenance procedures in your equipment manuals.
- Connect all disconnected equipment ground cables and wires after servicing equipment. Ground all conductive equipment.
- Use only approved TKH Airport Solutions replacement parts. Using unapproved parts or making unapproved modifications to equipment may void agency approvals, impair specified performance and create safety hazards.
- Check interlock systems periodically to ensure their effectiveness.
- Do not attempt to service electrical equipment if standing water is present. Use caution when servicing electrical equipment in a high-humidity environment.
- Use tools with insulated handles when working with electrical equipment.

---

## 3. General Recommendations

---

---

### 3.1 Receiving, Storage and Unpacking

---

- 1 Upon receipt of goods at the site store, check all packaging for visible damage. Every damaged box should be opened and its contents inspected for damage. If equipment is damaged, a claim form shall be filled with the carrier immediately. It may then be necessary for the carrier to inspect the equipment.
- 2 Store the light assembly preferably in its original packaging in a protected area. When stored unpacked, please take care not to damage the cable insulation.
- 3 Unpack the light assembly at the installation site to avoid damage during transportation and handling.

---

### 3.2 Electrical Connection

---

The light assemblies covered by this manual are designed for connection to 6.6-A series circuits via one or two L-830 or L-831 series transformers. The current to the light should not exceed 6.6 A + 5%. The series transformers are to be ordered separately.

---

### 3.3 Base Earthing

---

Whatever the chosen installation method, it is strongly recommended to earth the base, especially in locations presenting a risk of lightning strikes. Failure to earth the base correctly will void the warranty for all damages occurring as a result of voltage surges.

## 4. About the PAPI 801

The PAPI system is a simple and reliable visual aid which enables the pilot to establish and maintain an exact glide path. The system secures the safe and accurate guidance for the pilot throughout the final approach phase to touch-down, both day and night.

A standard PAPI system comprises a wing bar of 4 light units located alongside the runway on its left, at the glide path origin and facing the approach. If further horizontal guidance is required, a second wing bar on the opposite side of the runway can be established.

An APAPI system comprises a wing bar of 2 light units.

On approach, pilots are presented with a red/white light pattern that informs them instantly of their vertical position relative to the designated glide path, enabling them to adjust the rate of descent to acquire the correct glide slope or, if necessary, fly a low or high approach in complete safety.

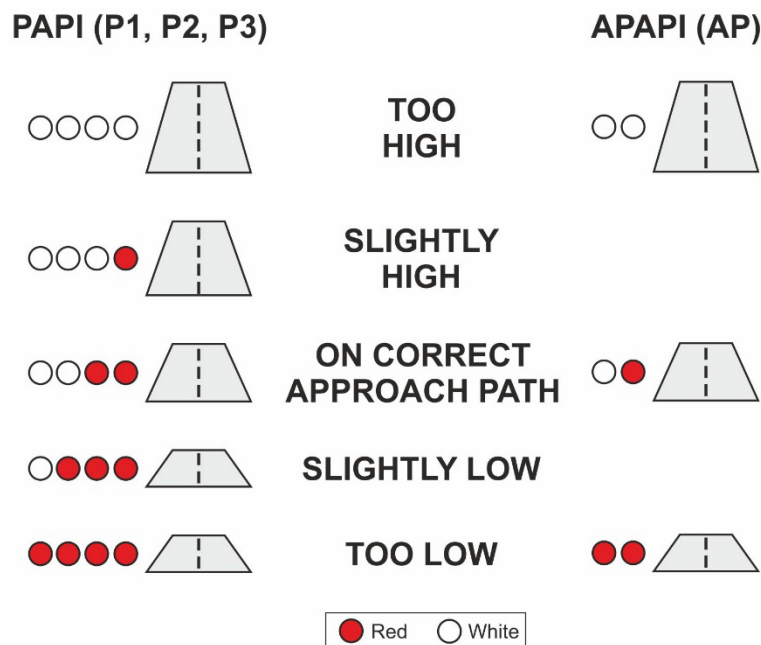

*PAPI and APAPI Light pattern*

This TKH Airport Solutions PAPI 801 can be supplied as 2-light units (2 x 200W Pk30d) or as 3-light units (3 x 200W Pk30d). As an option, the units can be supplied with heating elements on the lenses to prevent ice and / or mist.

## 4.1 Mode of Operation

The optical system divides the light beam of the units in an upper half showing white and a lower half showing red. The transition at the centre of the vertical range is of so short a duration that the lights give an eye-catching click within a range of less than 3 minutes of arc.

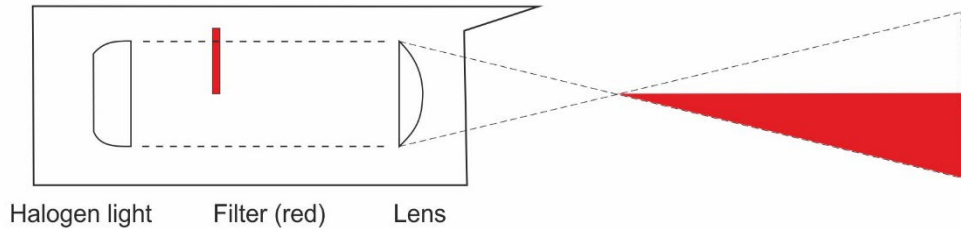

*Schematic illustration of the PAPI operation*

### Location on the Field

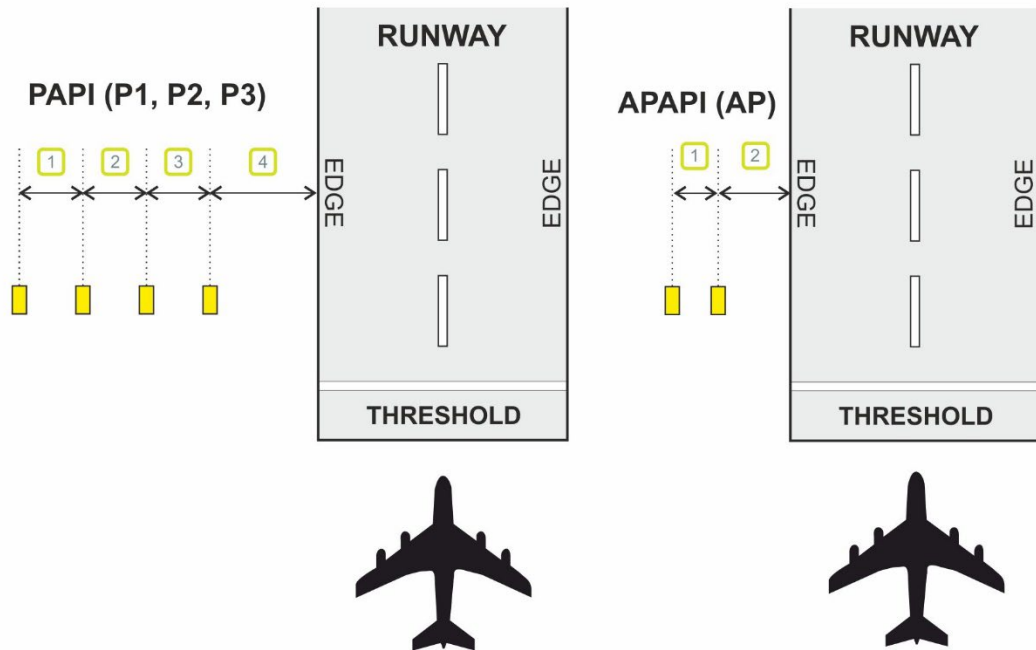

PAPI		APAPI	
1.	9 m +/- 1 m	1.	6 m +/- 1 m
2.	9 m +/- 1 m	2.	10 m +/- 1 m
3.	9 m +/- 1 m		
4.	15 m +/- 1 m		

### NOTICE

Light beam angles for each light need to be calculated for the airfield, depending on ILS and approach angles.

## 5. Description of the PAPI unit

The main parts in PAPI units are as follows:

- Stainless steel housing
- Stainless steel cover
- 3-legged bottom frame, with adjustable legs.
- Lenses
- Red filters with eccentrics for adjustments
- Halogen light sources
- Aluminium reflectors
- Control display for angle adjustment



The PAPI unit is constructed and adjusted to have the centre of the lamp, edge of red filter, and centre of lens in one line to secure the sharp transition.

In the factory, the PAPI unit is adjusted to 0° in both light directions and perpendicular to the light direction (measured on the control display). The following are checked and adjusted in that position:

- Light output is also 0°
- Transition sector is completely identical for all (2 or 3) light systems in the PAPI unit
- The transition sector is horizontal

The PAPI unit is now adjusted to a sharp transition between red and white, and the angle on the control display will be the same as the angle of the light output.

The angle of the light output can now be adjusted by setting the position of the ball joint on the back leg.

### 5.1 PAPI specification

- The PAPI units can be supplied with light plane height above ground between 350mm and 700mm. The standard value is 550mm. The height can typically be adjusted  $\pm 20$  mm.
- Light output app. 35.000cd (white) / 10.000cd (red) for one 200W light system. To be multiplied with 2, respectively 3 dependant on the number of lamps in the PAPI unit.
- Lamps: 200W-6,6A- Pk30d-1000Hour
- Weight approximately 40 KG
- Cover in aviation yellow, the rest is black.
- Breakable coupling included
- Foundation bolts are not included as standard. Standard 16mm hot dip galvanized bolts with accessories can be used or we can offer a stainless foundation kit type 801.530
- Cable entry for each lamp through PG 13,5 gland. Connection directly to male connector on Pk30 bulb as standard.
- Optional FAA cable can be supplied in length according to customer request
- The PAPI light fixture can optionally be equipped with a heater system including a heater for each lens and a thermostat. Total power is 75W with an input voltage of 48VAC. The heater kit is to order as type 801.845.

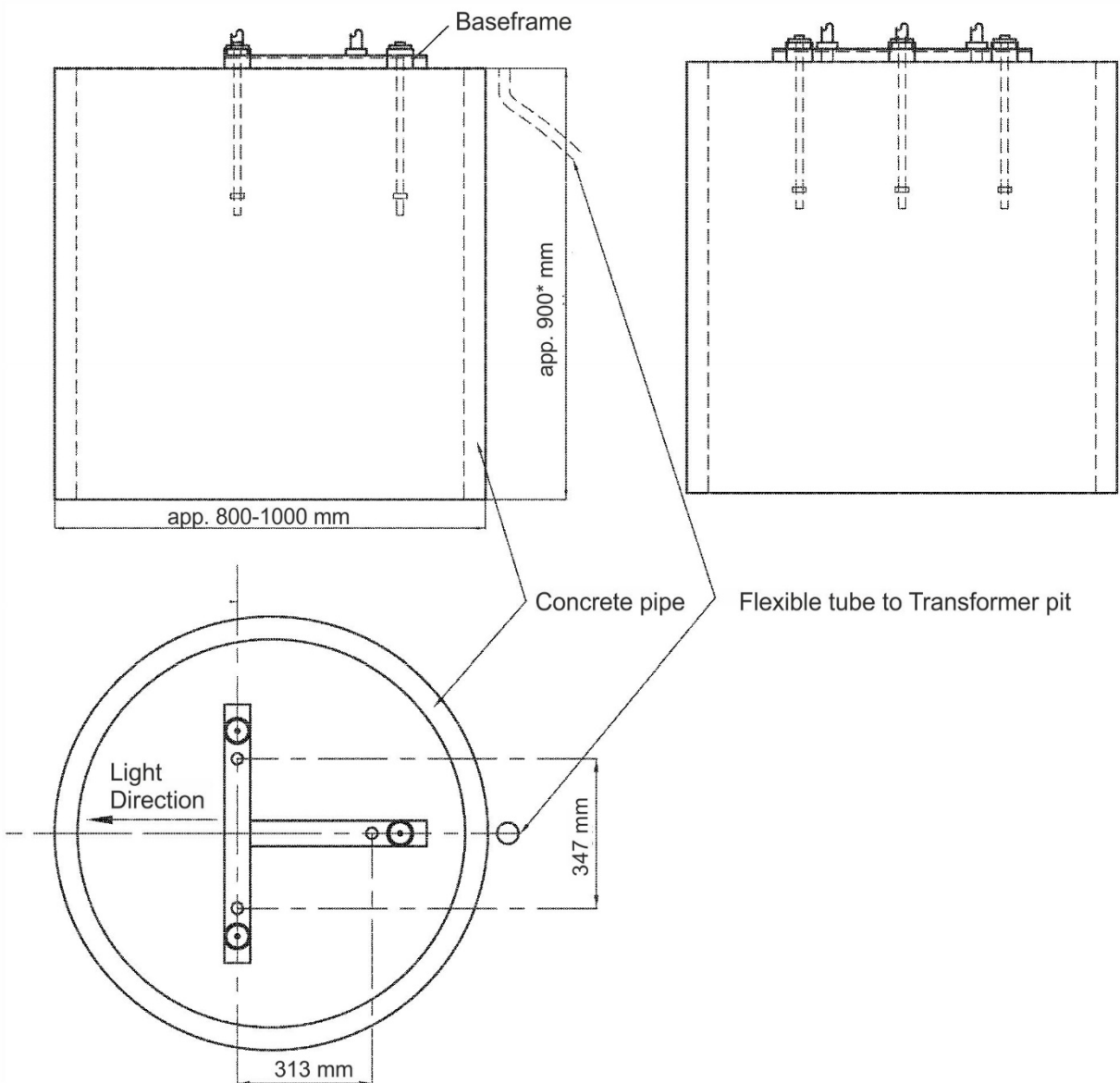
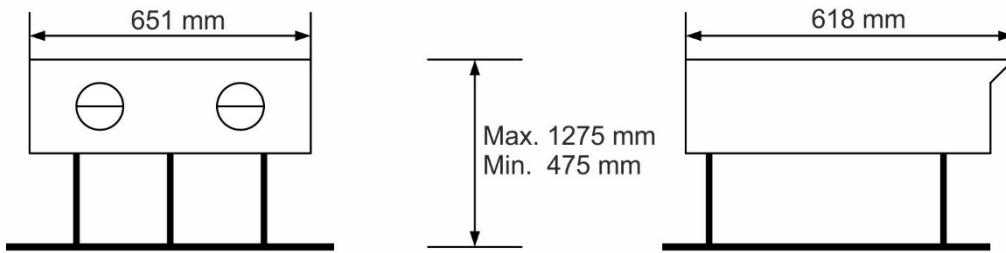

PAPI UNIT FOUNDATION

## 5.2 Assembly Drawing

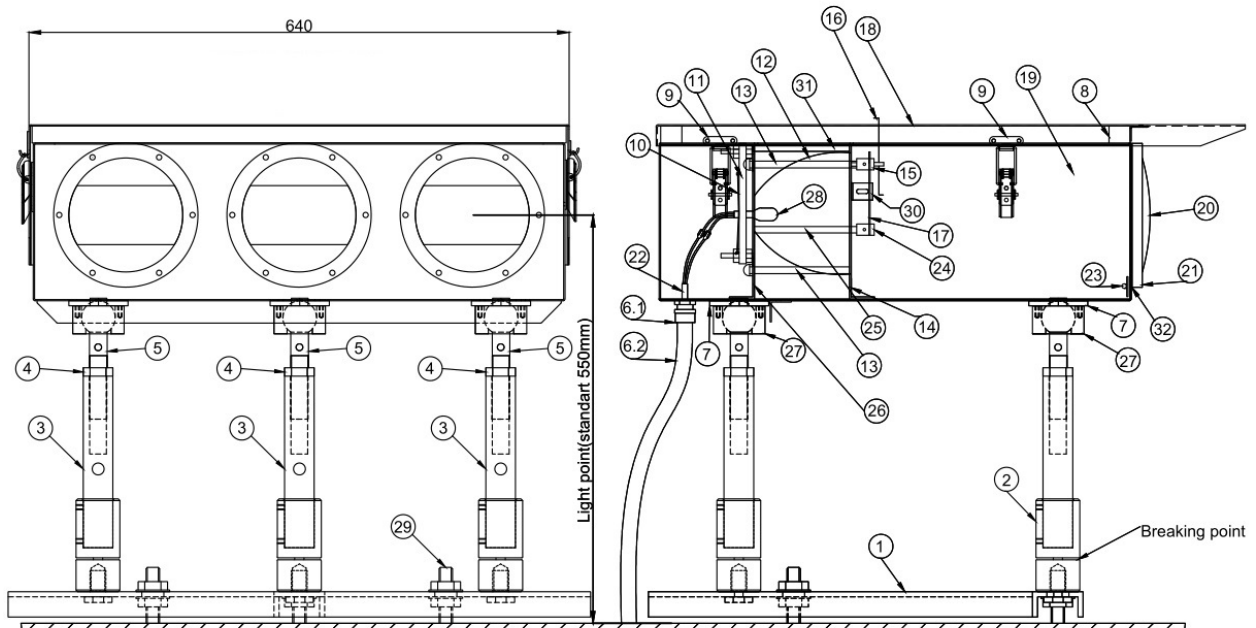

## 5.3 List of spare parts

Item	Description	Article number
1	Bottom frame	952204/2
2	Breakable coupling	952210/60-120
3	Pipe / PAPI legs (different sizes possible)	9522170XX
4	Nut 1/2"	P-900515
5	Ball bolt	801203
6.1	Fitting PG 13,5	P-242032
6.2	Protection tube	P-242031
7	Relief for ball joint	801220/1
8	Top / Back gasket	801858
9.1	Hook for Lock	P-855503
9.2	Lock without hook	P-855504
9.3	Pin for lock	P-855505
10	Spring for lamp holder	801419
11	Lamp holder	801418
12	Reflector	801416
13	Reflector holder threads	801406
14	Reflector housing	801815/3

Item	Description	Article number
15	Filter holder	801412
16	Spring for filter	801410
17	Red light filter	801432
18	Cover / Lid	801814/6
19	Housing	801810/4
20	Lens Ø150	801401
21	Lens holder ring	801403/1
22	FAA cable 2 pol 0.9 m	P-242010
23	Heater system for Halogen PAPI, 3 x 25 W - 42 V*	801845
24	Filter adjustment piece	801413
25	Adjustment holder	801414
26	Back plate for reflectors	801817/2
27	Ball joint	801222
28	Lamp PK 30d 200 W	P-383007
29	Anchor bolt	801530
30	Angle piece	40-5769
31	Adjustment bar	40-5964
32	Rubber gasket for lens	801433

\* Heating system is an option

**NOTICE**

When the PAPI 801 is configured with 2 lights, a cover plate is mounted in the center position.

---

## 6. Installation and Maintenance

---



Before any maintenance is done to the PAPI 801, the main power must be switched off.

---

### 6.1 Installation instructions

---

If the runway has ILS, the TDZ point for the PAPI system must be the same as the theoretical TDZ point for the ILS.

If not, the airport authorities can determine the TDZ point, or the minimum distance from the Threshold can be calculated as follows:

1. The minimum Threshold clearance is 15m.  
Runway is horizontal:  
Distance from Threshold = L (in m) =>  $L = 15 / \tan(\alpha)$ , where  $\alpha$  = glide slope angle
2. TDZ is D (in m) lower than Threshold:  
Distance from Threshold = L (in m) =>  $L = (15+D) / \tan(\alpha)$ , where  $\alpha$  = glide slope angle
3. TDZ is D (in m) higher than Threshold:  
Distance from Threshold = L (in m) =>  $L = (15-D) / \tan(\alpha)$ , where  $\alpha$  = glide slope angle

Placed in the TDZ point the PAPI units must have their light output center the light plane in level with the center of the runway. It means that the top of the foundation must be 550 mm (for a standard height of PAPI units) lower than the center of the runway. If that is not possible either the TDZ point or the PAPI units must be displaced.

1. Mount each PAPI unit on a stable concrete foundation by means of 3 anchor bolts. The light output must be parallel to the runway or have a very small toe-in.
2. Mount the PAPI units on the anchor bolts.
3. Level the bottom frame.
4. The fixation of the ball joint to the frame or housing is done with 3 M5 UNB screws. The torque required is 6Nm.
5. By means of the ball joints on each leg, adjust the PAPI unit to the correct light output plane with the housing approximately levelled.

## 6.2 Adjusting the correct light output plane

The ball joints on the 3 legs are adjusted until the PAPI light unit has the correct light output level, and at the same time the factory adjusted control plane in the PAPI unit is 0° in both light direction and perpendicular to the light direction. This is measured by means of the high accuracy digital clinometers, see the following figure.



Then the digital clinometer is placed on the control plane in the light direction, and the ball joint on the back leg is adjusted to the desired angle for each individual PAPI light unit. Be careful not to touch the housing during the adjustment as angle adjustment is very sensitive.

Please read the manual for the digital clinometers carefully before use to know how to handle this very sensitive, high-tech device. Please note, that the battery must be changed regularly to maintain the factory calibration of the digital clinometers.

## 6.3 Adjusting the red filter

The filters inside the PAPI can be adjusted in height and horizontal level.



### CAUTION

Do not adjust the distance between the filters and the lamp housing. This distance is pre-set in the factory and fixed.

A correct position of the filters can be seen from the front of the PAPI. The red filters should be aligned correctly (shown is the PAPI with 2 lights).

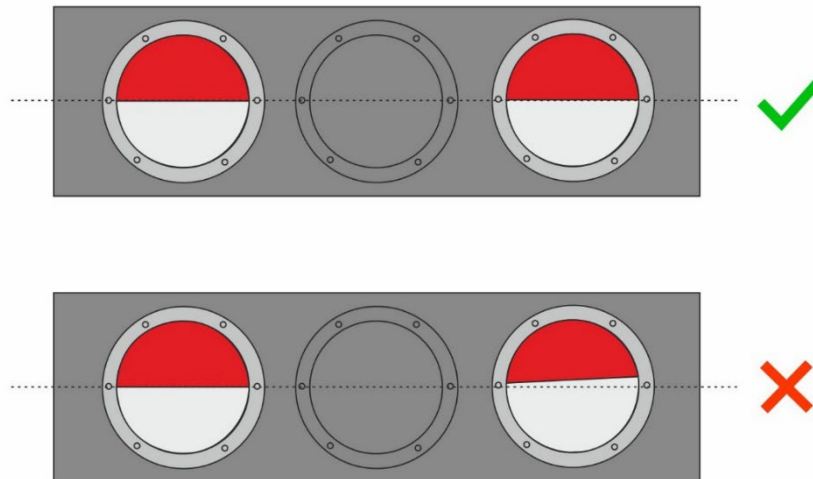

The transition line in both the lenses must be at the same height. If not, the filters can be adjusted by eccentric position screws. To adjust the transition line:

1. Switch the power off.
2. Lift the cover of the PAPI.
3. Adjust the adjustment screws (2) of the applicable filter (1). The adjustment screws (2) can be found next to the rear side of the halogen bulbs (3).

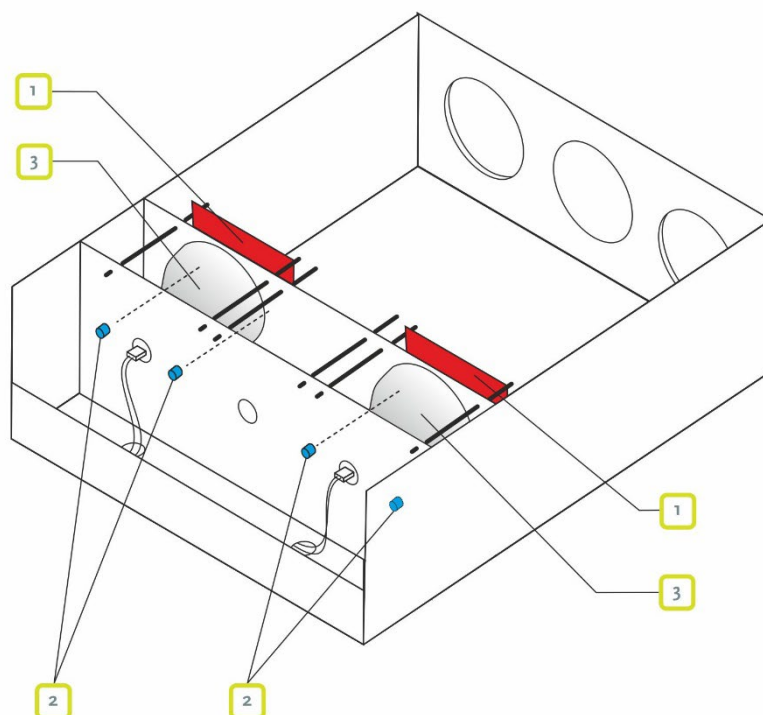

4. The adjustment screws are supporting the filter at two positions. The slots in where the filter is supported are eccentric. By turning the adjustment screws (2) on the back of the PAPI, the filter height (1) can be adjusted. The spring (3) keeps the filter in position onto the eccentrics (2).

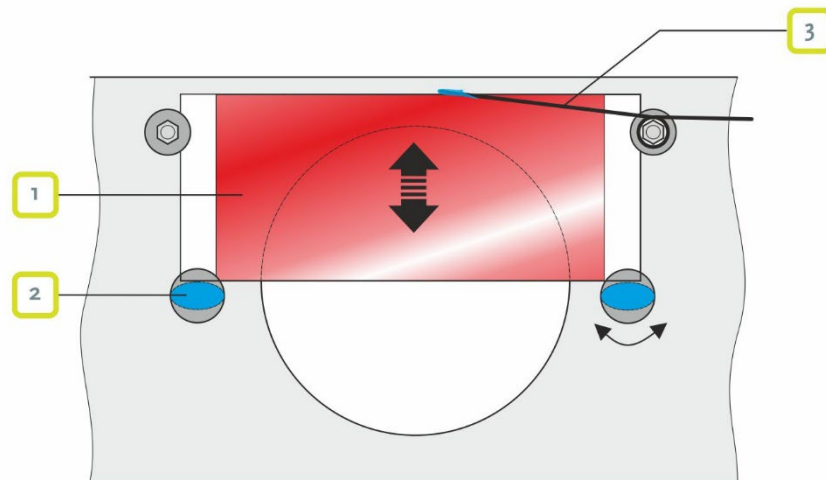

5. When the position of the filter is okay, mount the cover of the PAPI.
6. Switch the power on and adjust the correct light output plane, see 6.2.

---

## 6.4 Maintenance

---

Once a month the PAPI light fixtures should be maintained and controlled as follows:

1. The lenses are cleaned.
2. Reflectors and filters are carefully cleaned with a dry, soft cloth. If a filter is damaged, replace it with a new filter (see chapter 6.5).
3. Make sure, that the filters are in the correct position in the slots of the eccentric adjustment screws. If not, adjust the filter (see chapter 6.3).
4. Check that the lamps are working, and that the filament in the lamps is in the correct position (if the filament in the lamp starts "hanging" the transition sector for the actual light output will have moved).
5. Use the digital clinometers to control the setting of each PAPI unit, both in the light direction and perpendicular to the light direction.
6. Switch on the PAPI light in the highest intensity step, and look at the light output from the longest distance, where the transition from white to red can be seen. The transition must be sharp and simultaneous for all light system in the PAPI unit.
  - a. If not, control the position of the filters or
  - b. Change the lamps (be careful to place the lamp correct)

## 6.5 Replacing the red filter

If a red filter is damaged or worn (scratches), it must be replaced by a new filter.

1. Switch the power off.
2. Lift the cover of the PAPI.
3. Lift the spring (3) slightly (maximum 0,5 cm) by hand from the top side of the filter (1).

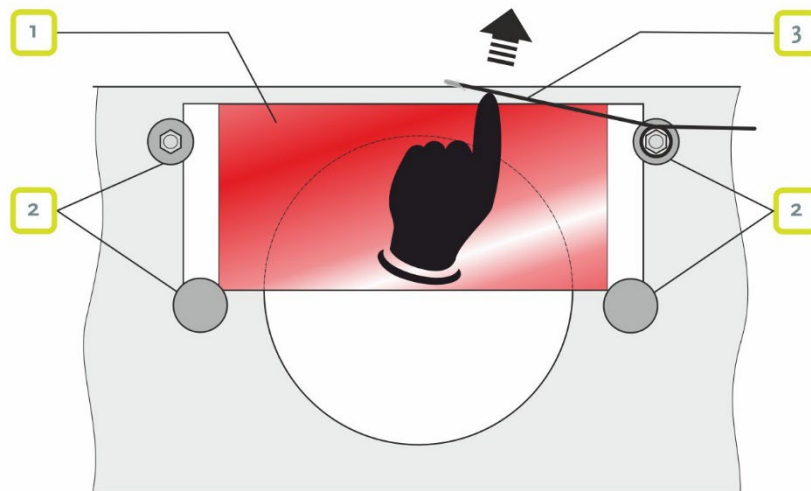

4. Move the hook (with the plastic protection cap) away from the filter and release the spring in front of the filter.
5. Lift the filter (1) out of the filter holders (2).

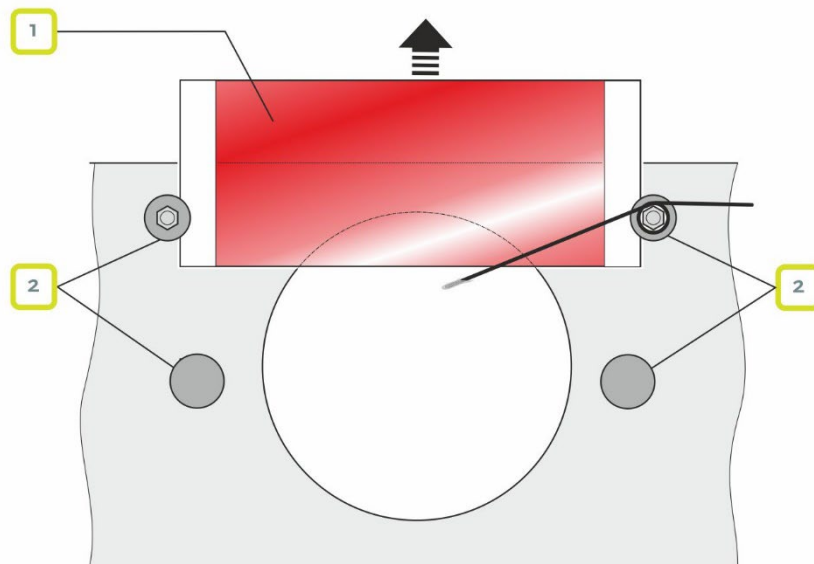

- Unpack a new filter (1).

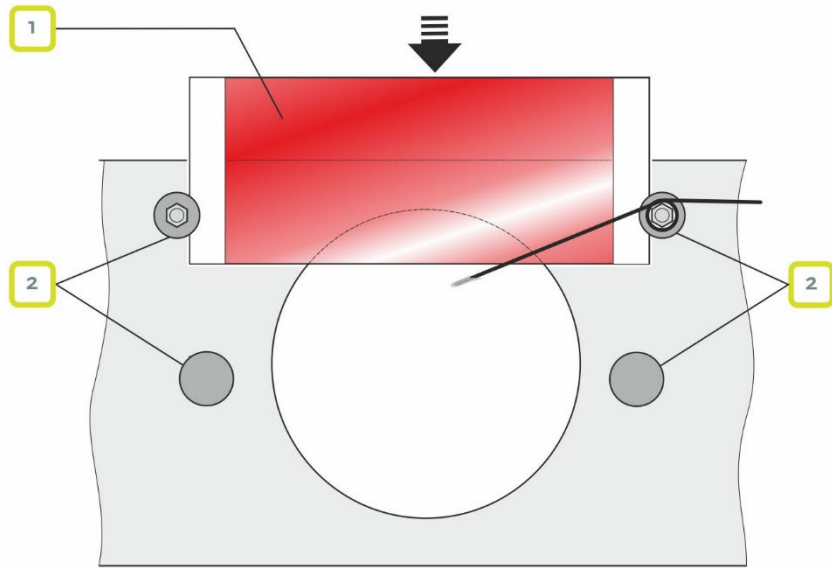

- Gently slide the filter (1) down between the filter holder (2) slots.
- When the filter (1) slots in the lower filter holders, replace the spring (3) back on top of the filter.

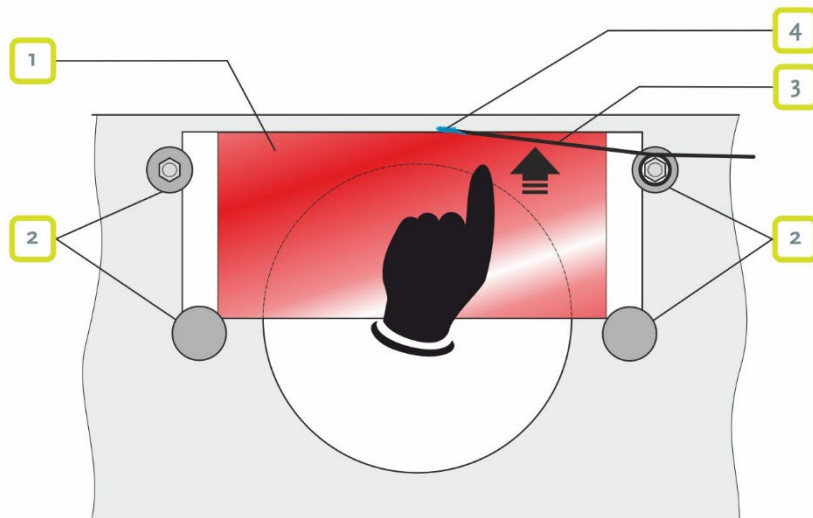

Be aware that the plastic protection cap (4) on the spring is still in place. This cap protects the filter from damages or scratches.

- When the spring is in place and the filter fits in all the slots of the filter holders, adjust the filter in height and horizontal level (see chapter 6.3).

## 6.6 Replacing the halogen bulb

Replacing the bulbs in a PAPI unit needs to be done with precision. If the bulb is installed incorrectly, it can result in a wrong light angle for that PAPI eye and further result in an unclear pink transition line (see pictures below).



*Clear transition between white and red*



*Unclear transition between white and red because of incorrectly installed bulb.*

Follow below instructions when replacing the halogen PAPI bulb.

1. Unmount the old bulb. You will now look at the lamp holder that has a groove in the metal fitting the bulb's mounting frame. As seen in the picture of the lamp holder, it has a rectangular slot in the top and a half circle slot in the bottom.

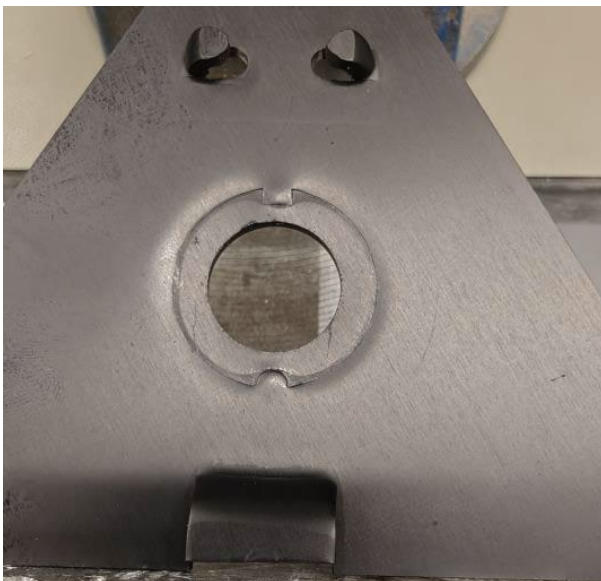

2. Follow the pictures below for the correct direction of the bulb.

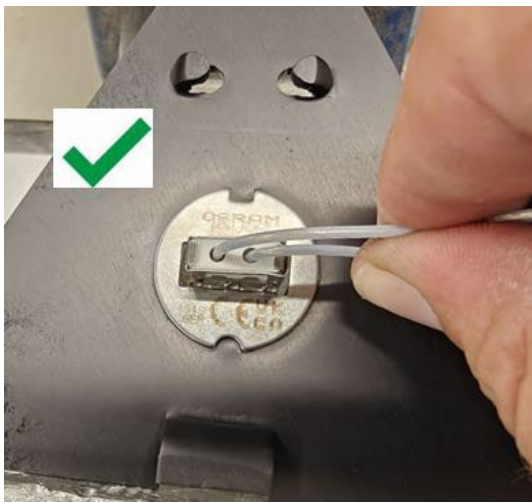
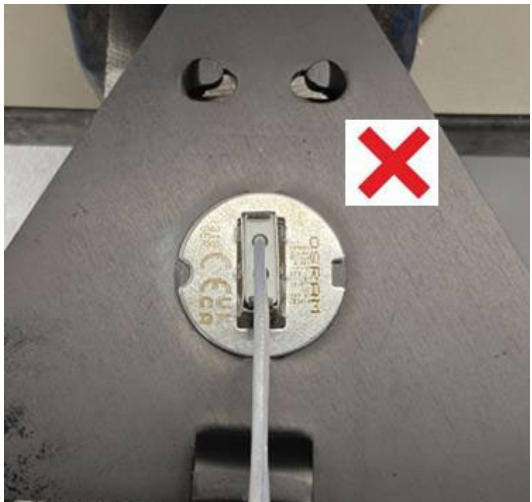
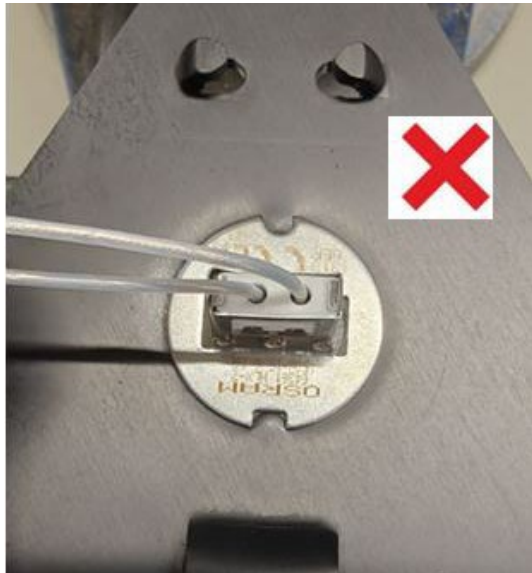
	<p><b>CORRECT</b> - The rectangular cut and the half circle cutout of the bulb mounting frame is fitting with the slots in the lamp holder</p>
	<p><b>WRONG!</b> - The bulb is turned 90 degrees. The bulb is not fitting in the slots of the lamp holder.</p>
	<p><b>WRONG!</b> - The bulb is turned 180 degrees. The half circle cutout in the bulb mounting frame is not fitting with the rectangular slot in the lamp holder.</p>

This page left intentionally blank



### Company profile:

TKH Airport Solutions is an innovator in airfield ground lighting, offering a complete range of LED AGL products. We build upon the know-how from a long and successful tradition of pioneering developments in the AGL and connectivity industry. Being part of the TKH Group, our company can build on a history of more than 90 years in smart connectivity, energy distribution and AGL.

#### More information:

**TKH Airport Solutions**  
sales@tkh-airportsolutions.com  
www.tkh-airportsolutions.com  
+31 (0)53 57 414 56

#### Visiting address

**TKH Airport Solutions**  
Elektrostraat 17  
7483 PG Haaksbergen  
The Netherlands