

Datasheet

Breakable Coupling (A and C)

General

Each elevated light fixture must have a yield point near the point or position where the light attaches to the base plate or mounting stake. The breakable coupling gives way before any other part of the fixture is damaged.

Standards

TKH Airport Solutions breakable couplings have been developed according to the following standards:

- ICAO ADM Part 6
- FAA AC 150 / 5345-46

Variants

There are 4 variants, depending on the mounting position and the type of TKH Airport Solutions light:

Coupling type	for elevated light type	use
A	6.6A LED-AGL 792, 241 and HIRE	for ground mounting
A (797)	6.6A LED-AGL 797	with 2" thread (European standard thread or 11.5 NPT or NPS)
C	6.6A LED-AGL 792, 241 and HIRE	for 2" pole mounting
C (CEDD)	CEDD® elevated lights	for ground or pole mounting

Specifications

- Material: Anodized Aluminum
- Corrosion-proof
- Weight: approximately 0.2 kg
- Type C: exterior finished in aviation yellow
- TKH breakable coupling is calculated and tested to break at 45 kgm ± 4 kgm which is in accordance with FAA AC 150/5345-46E and ICAO ADM Part 6

Dimensions

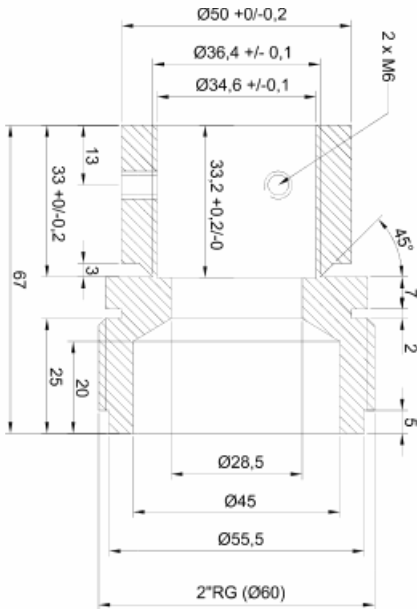

Type A

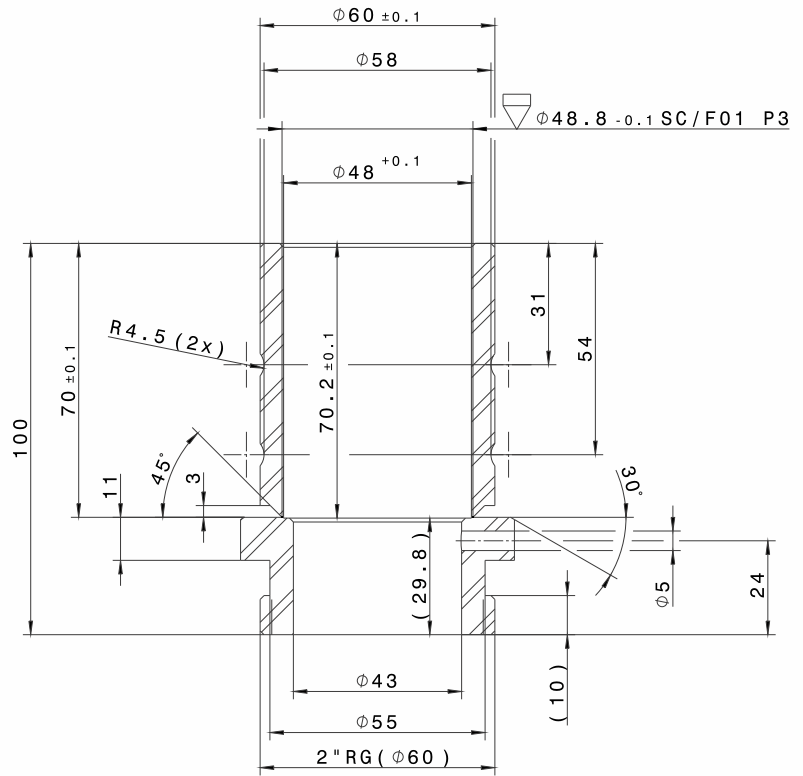

Type A (797)

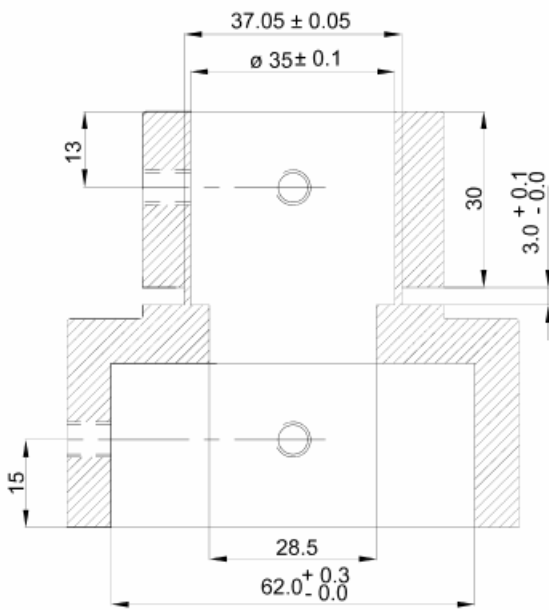

Type C

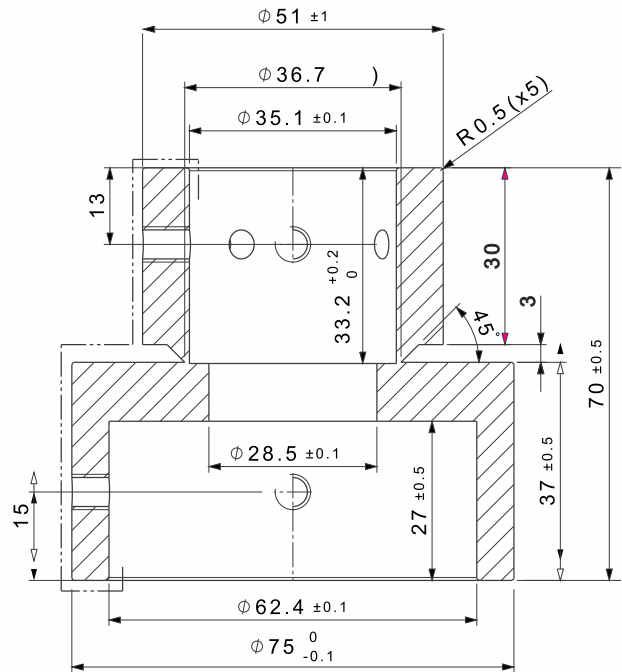

Type C (CEDD)

Ordering code

Ordering code	Description
790.518/2	Breakable coupling type A with stop for elevated lights 6.6A LED-AGL 792/HIRE/241 family
230.129-00	Breakable coupling type A for ground mounting of 6.6A LED-AGL 797 family
790.901/2	Breakable coupling type C for 6.6A LED-AGL elevated lights 792/HIRE/241 family
790.902/2	Breakable coupling type C for CEDD [®] elevated lights

Document Information

Name : 04_Breakable_Coupling_Type_A_and_Type_C_03-71064
Version : V2.0
Language : English (Original manual)

For the latest version of this document see <https://www.tkh-airportsolutions.com/airfield-products/> or scan:





Company profile:

TKH Airport Solutions is an innovator in airfield ground lighting, offering a complete range of LED AGL products. We build upon the know-how from a long and successful tradition of pioneering developments in the AGL and connectivity industry. Being part of the TKH Group, our company can build on a history of more than 90 years in smart connectivity, energy distribution and AGL.

More information:

TKH Airport Solutions
sales@tkh-airportsolutions.com
www.tkh-airportsolutions.com
+31 (0)53 57 414 56

Visiting address:

Elektrostraat 17
7483 PG Haaksbergen
The Netherlands